

SALOG Aerotechnic

SALOG Trade ways Pvt Limited
Aerospace, Automobile Components & Sub-assemblies



Corporate Office :

SALOG Tradeways Pvt Limited
Sumuk Paradise SF-4, Ms Palya Near Aveksha Hospital Vidyanarayapura Bengaluru, Karnataka 560097 - India
T: +91 73 493 40484 | +91 98864 00011 | E : operations.ind@salog.co | W: www.salog.co

Aerospace, Automobile Components & Sub-assemblies

Product Profile



Aerospace, Automotive & Defense:

- a. Engine Parts
- b. Structural Parts
- c. Helicopter Components
- d. UAV Systems
- e. Missile parts & Systems.
- f. Rifle Chassis

Aircraft Structural Components

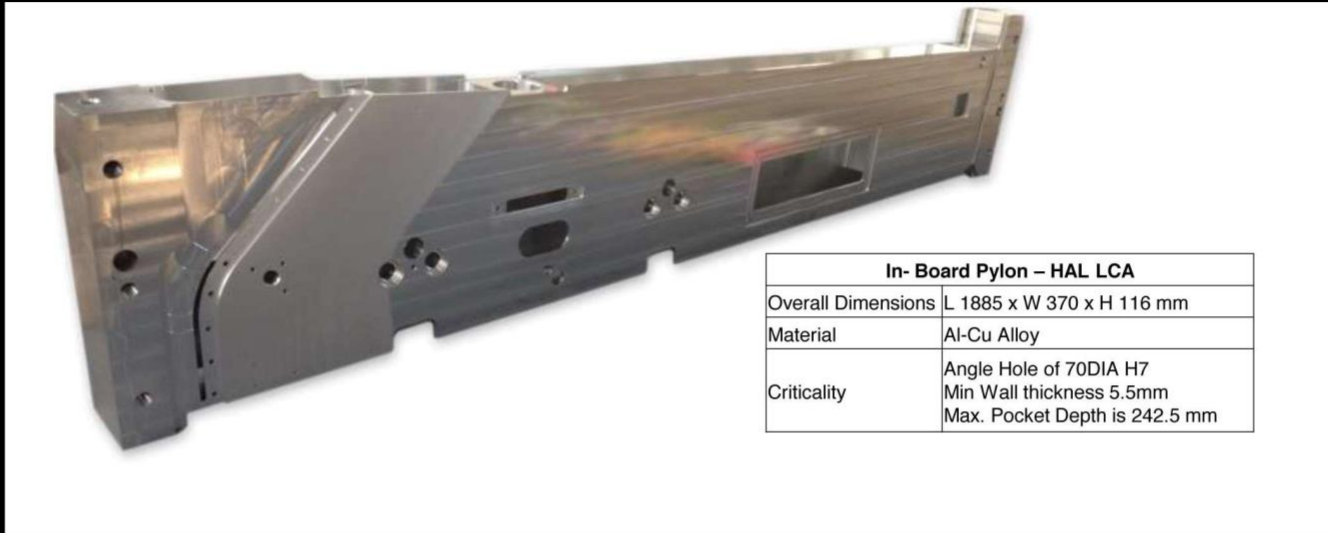

In- Board Pylon – HAL LCA	
Overall Dimensions	L 1885 x W 370 x H 116 mm
Material	Al-Cu Alloy
Criticality	Angle Hole of 70DIA H7 Min Wall thickness 5.5mm Max. Pocket Depth is 242.5 mm



Top Channel (AV/FV) – HAL-LCA	
Overall Dimensions	L 640 x W 91.50 x H 30 mm
Material	Al-Cu Alloy
Criticality	2.5 mm min. Wall thickness



Top Channel – HAL LCA	
Overall Dimensions	L 270 x W 89 x H 28 mm
Material	Al-Cu Alloy
Criticality	2 mm min. Wall thickness

Helicopter Structural Components



Rotor Mast Bearing Housing – HAL ALH	
Overall Dimensions	OD 800 x ID 550 x H 77 mm
Material	Ti Alloy
Criticality	Angle Hole 3°11' of Dia 20, H7 Pocket Milling 5 mm width Turning 674 g6, 556 H7, True Position $\oplus \phi 0.02$



Drag Links

Missile Sub Assembly Components



Clamping Ring



Support



Insert



Lining



Obturator Assembly

Obturator Assembly - BATL	
Overall Dimensions – Support	OD 670 x ID 595 x H 50 mm
Overall Dimensions – Clamping Ring	OD 646 x ID 596 x H 26 mm
Material	AK4 1T1
Criticality	Assembly Milling, Match drilling

Decoy System Components (Submarine)

Decoy System Components (Submarine)



Arming Device Body – BDL-Vizag	
Overall Dimensions	OD 140 x H 95
Material	ANSI 316 L
Criticality	Boring, Angle Boring, Key way milling, Internal and External Pressure Testing

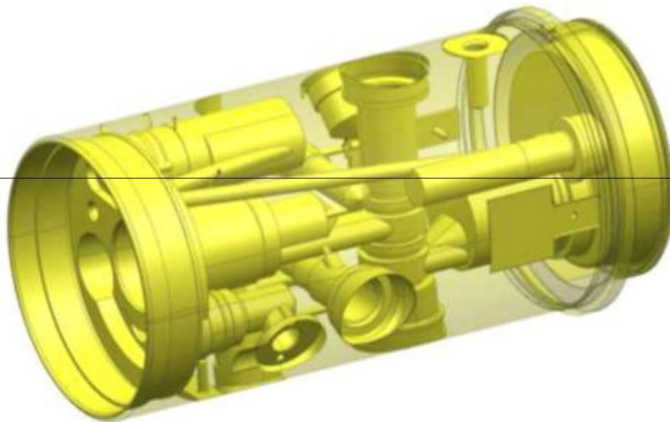

Manifold 5" (Under Development) – BDL-Vizag	
Overall Dimensions	OD 150mm X L 292 mm
Material	X2CrNiMoN 22-5-3
Criticality	Boring concentricity with in 20 micron, Angle Boring, 4mm Drill up to 150 mm deep, 2 mm drill up to 70mm deep, 8 drill upto 290 mm deep, M4 thread at 70mm deep, Dia 12 oblong slot is 175 mm deep, Pressure Testing

BEL/DARE Interface Beam Assembly

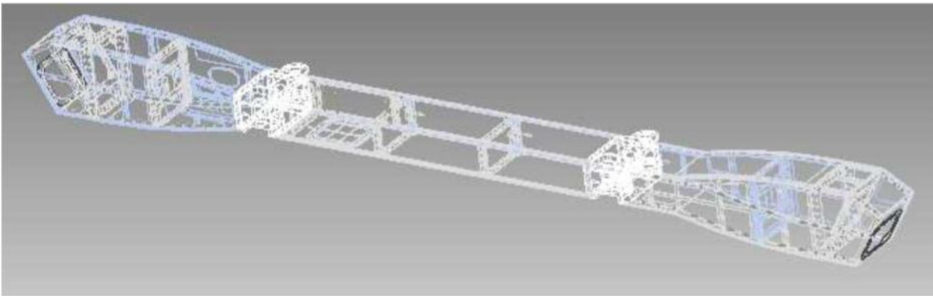
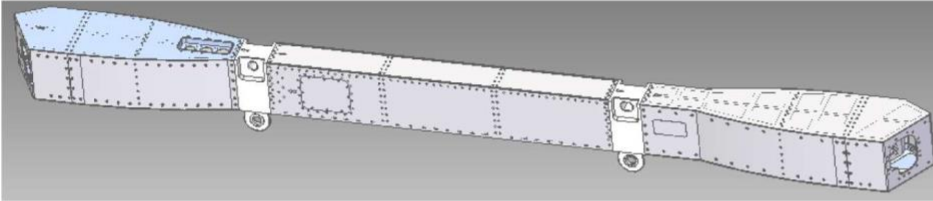

Assembly consists of 15 types of components and 27 types of Fasteners

Material and Process Details

Maraging Steel	Machining
	Heat Treatment
Aluminium	Machining
	Match & Drill
	Riveting
	Hard Anodizing
Aluminium Sheet Metal	LASER Cutting
	Annealing
	Bending & Forming
	Heat Treatment
	Match & Drill
	Riveting
	Hard Anodizing
SS 316	Machining
	Passivation
Final Assembly	

Projects Executed

We design and build electro-mechanical test systems for Aerospace and Automotive industry.





Projects Executed



Projects Executed

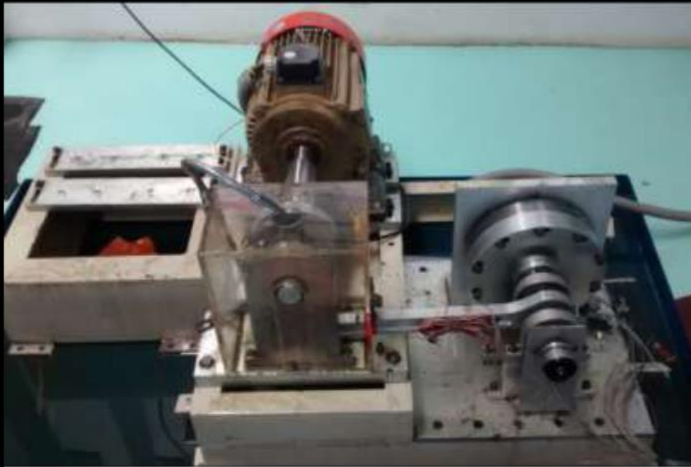

Projects Executed

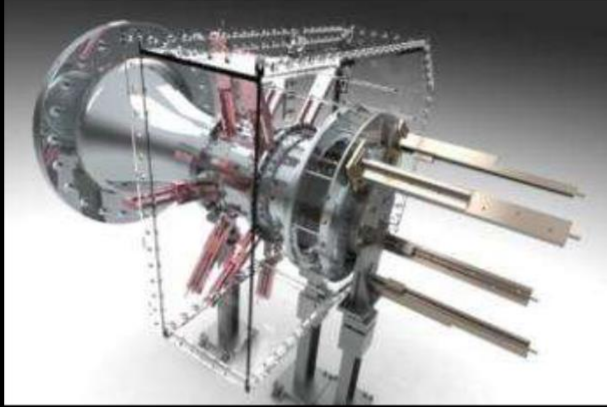

Diffuser

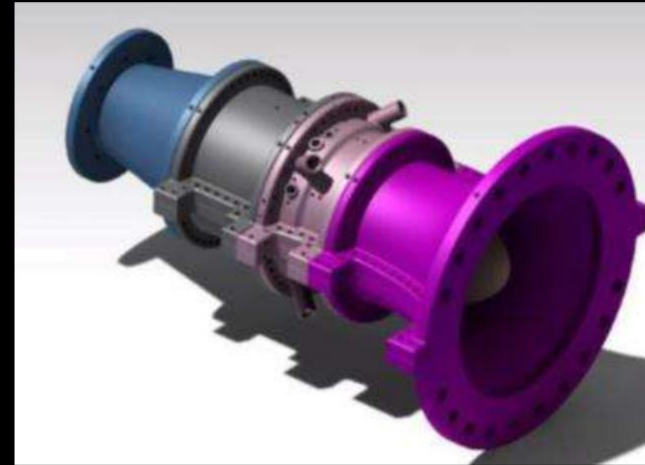

Extraction Cavity

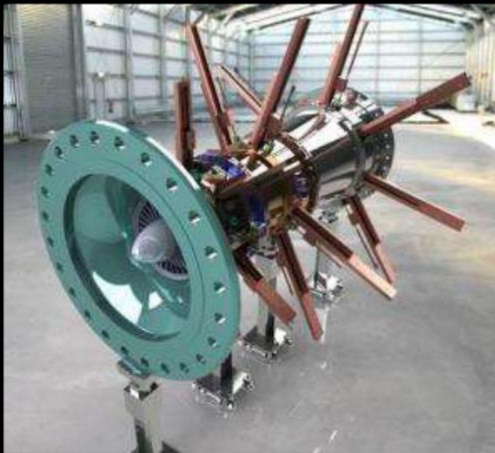

Advanced Diffuser



Wet Compression Rig

Additive Manufactured Components

Name: Cooling
impeller vein

Material: Aluminum



Name: Golf ball
mould

Material: Steel



Name: Turbine blade

Material: Titanium



Name: Propeller

Material: Inconel



7.62 x 51 mm Chassis Sub MOA Sniper Rifle

- Increases accuracy by up to 21%
- CNC Machined from 6061 T6 Aluminium.
- Anodized Matte Black Finish
- M-Lok pattern attachment system on all 5 faces of the fore-end.
- Lightweight, free-floating modular forend.
- Will accommodate barrels up to 1.350" diameter.
- Weight: 1.5 kg – 1.9 kg, depending on the rifle model.



Top Rail



Butt Stock



Chassis

Fully Assembled 7.62 x 51 mm Chassis Sub MOA Sniper Rifle

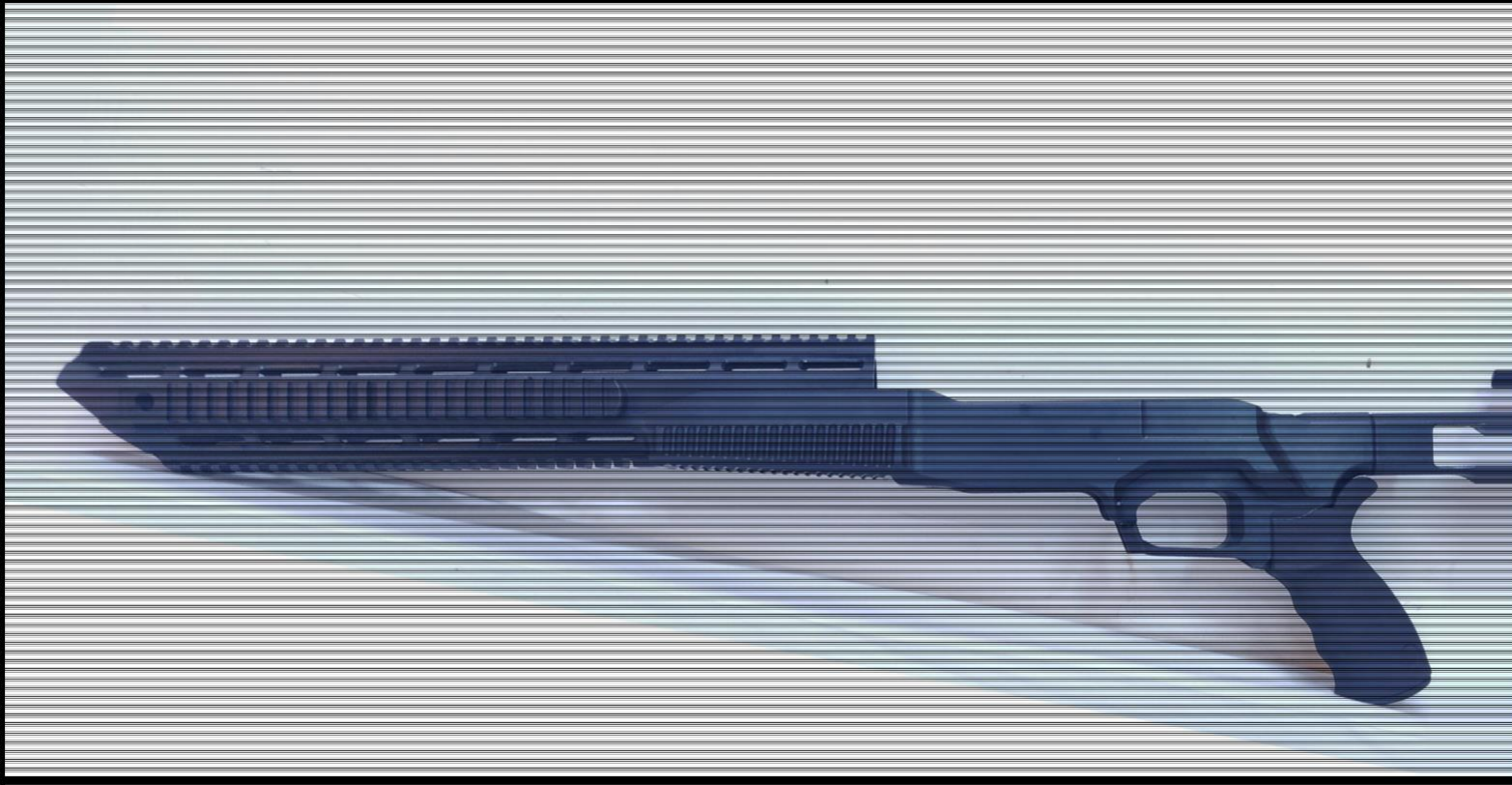



Legacy AK-47 Upgrade

- The ingeniously simple and rugged design provides a rock solid mount for accuracy and a forward hinged, quick release cover with rear cam lock design to preserve the AK's field stripping qualities.
- Designed as part of an integrated system the Hand Guard offers greater levels of functionality, modularity, and durability.
- The coplanar top rail keeps all accessories such as optics, night vision, or thermal devices properly aligned.
- For additional functionality the handguard is also M-LOK compatible. Ample ventilation holes assure the quickest cooling and minimize weight.



Receiver cover



Hand Guard

Full Metal M LOK Hand Guard for MP 5

- Each handguard will accept your choice of picatinny rails on both left and right sides as well as the bottom that can be added and taken off at will.
- Ample ventilation holes assure the quickest cooling and minimize weight.
- Designed as part of an integrated system the Hand Guard offers greater levels of functionality, modularity, and durability. For additional functionality the handguard is M-LOK compatible.



Full Metal M LOK hand guard

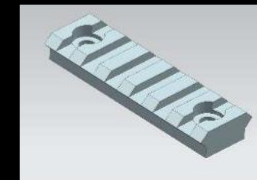

7 Segment Picatinny Rail

M 9 Links



Material : Carbon Steel

Description : M 9 Links

Caliber : 0.50 Caliber Machine Gun

Weight : 15-16 Grams.

M 13 Links:



- **Material : Carbon Steel**
- **Description : M 13 Links**
- **Caliber : 7.62 x 51 mm Cartridge**
- **Weight : 7 Grams**
- **Finish :**
 - E- Coat
 - Phosphate

M 27 Links:



- **Material : Carbon Steel**
- **Description : M 27 Links**
- **Caliber : 5.56 x 45 mm Cartridge**
- **Weight : 4 Grams**



12.7 x 99 Sabot



- **Material : SAE 12L14**
- **Description : 12.7 x 99 mm Sabot**
- **Caliber : 0.50 Caliber**
- **Weight : 26 Grams**

12.7 x 108 Sabot



- Material : SAE 52100
- Description : 12.7 x 108 mm Sabot
- Caliber : 0.50 Caliber
- Weight : 31 Grams



12.7 x 99 Sabot



- **Material : CuZn36Pb3**
- **Description : 12.7 x 99 mm Sabot**
- **Caliber : 0.50 Caliber**
- **Weight : 45 Grams**

5.56 x 45 Steel Insert



- Material : EN 8
- Description : Steel Insert
- Caliber : 5.56 x 45 mm



7.62 x 51 Steel Insert



- Material : EN 8
- Description : Steel Insert
- Caliber : 7.62 x 51 mm

UAV



UAV





Repair and Overhaul Of Legacy Aircraft

•Our goal is to reduce your per hour costs of legacy aircraft and provide upgrades to meet today's mission requirements for the following models:

- Sikorsky S61 series
- Sikorsky SH-3 series
- Sikorsky UH-3 series
- Sikorsky VH-3 series
- Sikorsky CH124 Sea King
- Augusta AS-61 series
- Westland Sea King
- Westland Commando





Mission Equipment Upgrades

- NVG
- Hoist kit, Cargo Hook
- FLIR / EVS
- Night Sun
- Countermeasure Dispenser
- Missile Warning System
- Floats
- Aeromedical Interior





Maintenance

Our team can reduce your operating Costs and downtime by offering the following:

- Major or minor Inspections and Depot Level
- Maintenance (DLM)
- Repairs
- Refurbishments
- Kit installations
- AD's, STC's
- Troubleshooting
- Upgrades





Structures

Exchange items are available including doors, oil pans, tail booms, and transmission platforms

Structures and maintenance crews, can travel at a moments notice to assist your fleets mission ready capabilities, anywhere in the world.

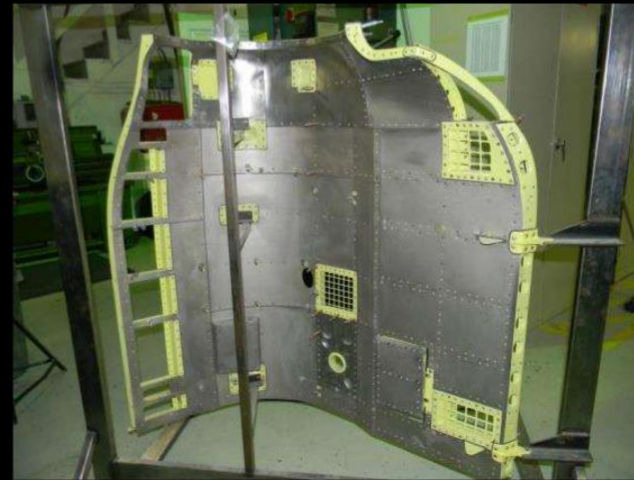



Structures

Structural Repair and Overhaul capabilities:

- Pylon
- Doors, air stair doors, and cowlings
- Sponson and airframe landing gear fitting
- Tail cone
- Station 243 and 290 frame repair and replacement
- Airframe Main gearbox fitting replacement
- Lower tub and keel repairs





Composites

- Our technicians have been extensively trained in all aspects of composite repairs.
- We can assess and accurately estimate your composite requirements which do not exceed pricing and expedite your component back to service.
- Exchange items are available to reduce downtime on your fleet.





Component Overhaul

- Overhaul solutions for all aspects of your maintenance needs, from minor repairs to complete aircraft and component overhauls.



Machinery at our Partner Company in Bangalore India



DMG Mori- DMU 75, 5-axis Machine

Machinery at our Partner company in Bangalore India



VMC (Hass Make-1500 x 550 x 63 mm)

Machinery at our Partner company in Bangalore India



Turning (Pride Make- 200 dia)

Machinery at our Partner company in Bangalore India



VMC (1000 x 510 x 510 mm)

Machinery at our Partner company in Bangalore India



Milling VF (BFW)



Jig Boring (Oerlikon)

Machinery at our Partner in Bangalore India



Surface Grinding (Meagerly)



Drilling Machine (IFFICO)

Machinery at our Partner in Bangalore India



V-Shaper Printer



SLM 500 Metal Printer

Machinery at our Partner Company in Bangalore India



Zeiss Comet Scanner



Hexagon Arm Scanner

Quality Control and Quality Assurance



Digital 2D height gauge



CMM



Corporate Office :

SALOG Tradeways Pvt Limited

Sumuk Paradise SF-4, Ms Palya Near Aveksha Hospital Vidyananyapura Bengaluru, Karnataka 560097 - India

T: +91 73 493 40484 | +91 98864 00011 | E : operations.ind@salog.co | W: www.salog.co